

Lorenzoni Srl
 Soc. Unipersonale
 Via Molini 98/3
 36055 Nove (VI) Italy
 P.IVA e C.F. 02872270240
 R.I. 02872270240 – R.E.A. 280950

CAVI SCALDANTI – RESISTENZE ELETTRICHE – TERMOREGOLAZIONE
 HEATING CABLES- HEATING ELEMENTS – TERMOREGULATION

Tel. +39 0424 502042
 Fax + 39 0424 502043
 info@lorenzoni-srl.it
 www.lorenzoni-srl.it

LOR FOIL KIT 0.3

Riscaldamento elettrico
 per pavimenti in legno e laminati
 Electrical heating
 for wooden and laminate floors



DESCRIZIONE

LOR FOIL KIT 0.3 è un KIT completo per il riscaldamento elettrico a pavimento per interni, installabile sotto pavimenti in legno e laminato. Il kit è composto da una pellicola isolante di 0,3 mm estremamente robusta su cui è inserita la lamina V. 230, un cronotermostato digitale (modello LOR-THERM 355), cavi di alimentazione, connessione e terminazione. La posa risulta pratica e veloce perché la pellicola si srotola come un tappeto e può essere tagliata in base alla superficie da coprire. Non contiene alogeni o PVC.

DESCRIPTION

LOR FOIL KIT 0.3 is a complete kit for electric underfloor heating for indoor, installed under wood flooring and laminate. The kit is composed of an insulating film of 0.3 mm extremely robust (on which is inserted the foil V. 230), a digital timer (model LOR-THERM 355), power cables, connection and termination. The installation is quick and easy because the film is unrolled like a carpet and can be trimmed according to the surface to be covered. It does not contain halogens or PVC.

Installation instructions Lor Foil Kit 0.3 100W

Read carefully through all the installation instructions before starting the installation

Before you start, compare the material in your Lor Foil Kit 0.3 with the table below.

Contents Lor Foil Kit

ARTICLE	UNIT						
Foil	(m)	13,5	18	22,5	27	31,5	22,5
Thermostat	(pcs)	1	1	1	1	1	0
Flexible conduit	(pcs)	1	1	1	1	1	0
Terminals	(pcs)	20	20	20	24	24	20
RTK cable black	(m)	6,25	6,25	8	8	8	6,25
RTK cable blue	(m)	6,25	6,25	8	8	8	6,25
Fixing tape	(pcs)	1	1	1	2	2	1
Sealing tape green	(pcs)	20	20	20	24	24	20
Insulating tape black	(m)	0,54	0,54	0,54	0,65	0,65	0,54
Installation instruction	(pcs)	1	1	1	1	1	0

General instructions

- Check that the foil is labelled for 230V and 100 W/m².
- Lor Foil Kit 0.3 must only be installed in dry areas.
- The installation must be connected via a 30mA earth fault relay.
- The foil must be laid with the copper strips facing down.
- Do not install when the temperature is below +10°C.
- The thermal conductivity of the flooring material must be more than 0.16 m²K/W.
- The foil must be protected from damage. The floorcovering must be laid immediately after the foil has been laid.
- The foils must be covered with non-ageing plastic film, at least 0.2mm, before the floor is laid.
- Crimping tool must be used, otherwise the guarantee will be invalid.
- The foil must not be laid under fixed fittings such as kitchen units, wardrobes, internal walls, etc., since this leads to overheating, and not close to stoves or other heat sources.
- Insulating interior furnishings such as thick carpets or floor cushions must not be used.
- The maximum load per foil is 10 A. Above 10 A load, the foils must be divided up and connected via a contactor.
- The foils must be controlled by a Lor-Therm 355 thermostat.
- Lorenzoni srl's single core double insulated cable (RTK) supplied must be used.

Configuration 1 is used where the floorcovering is wood/laminate

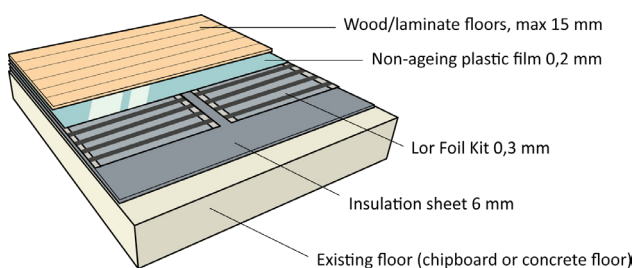

Configuration 2 is used where the floorcovering is plastic matting

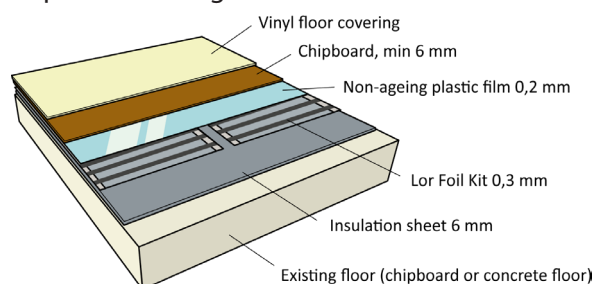

The underfloor heating system is a main voltage installation and must therefore be installed and connected in accordance with the current national regulations.

Preparing to lay the foil

In addition to the Lor Foil Kit 0.3 you will need:

- Non-ageing plastic film
- Insulation 6 mm
- Crimping tool
- Earth fault relay – if not already installed in the building

Remove any existing plastic matting.

Existing plastic matting must be removed, since the plasticiser in the matting may eventually damage the insulation sheets.

Planning how to lay the foil

Make an accurate sketch of the floor and draw in the positions of the lengths of foil. Points to think of when drawing the sketch:

- The position of the thermostat should take account of the power supply. Do not position the thermostat where it will be in direct sunlight at any time.
- The lengths of foil must be butted edge-to-edge. The foils must cover as large an area as possible, but the lengths of foil must not be pulled apart, since the differences in temperature will be noticeable.
- The total width of the foil is 43cm. The foils may be laid slightly overlapping, **but the distance between the copper strips must never be less than 5 mm.**
- It's important to ensure optimum cover where you will often stand, for example in front of the kitchen units.
- To avoid draughts, plan for the foils to be laid right up to outside walls.

Figures 1 to 3 below show various possible ways of laying and connecting the foils.

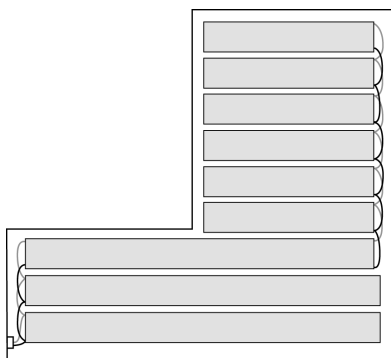

fig. 1

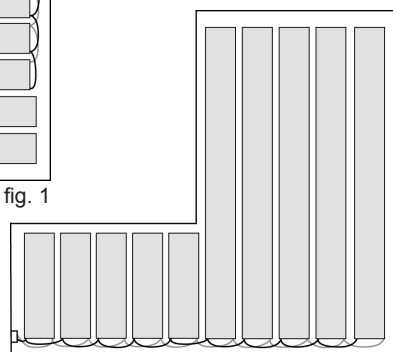

fig. 2

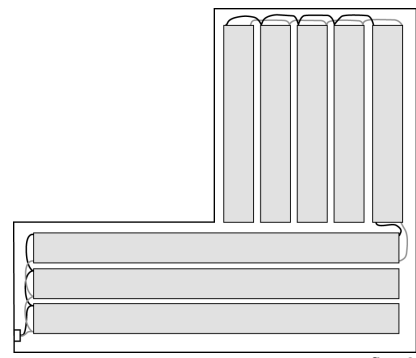

fig. 3

If there are obstacles:

If there is an obstacle in the way, cut the foil square and fit jumper wires around the obstacle, as shown in figure 4.

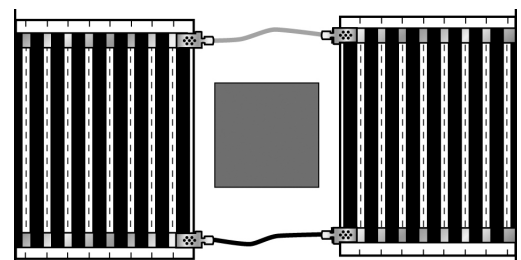

fig. 4

Getting started

Make space for the flexible conduit

Cut or chase a channel for the flexible conduit, as shown in figure 5. The end of the flexible conduit must be positioned centrally under a foil. The bend in the flexible conduit must not be too sharp or it will be difficult to insert the floor sensor. Feed the sensor into the flexible conduit and tape off the end.

Vacuum-clean the area thoroughly.

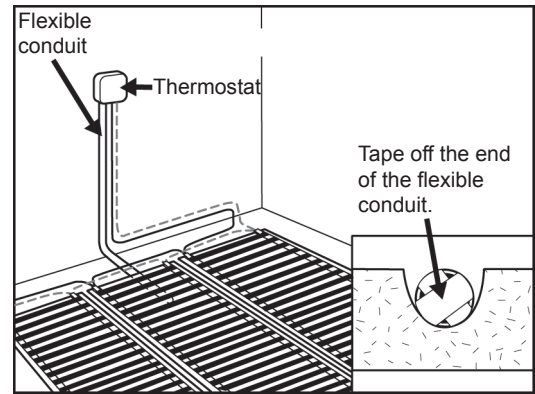

fig. 5

Lay the insulation

Lay the insulation sheets butted edge-to-edge. Leave a gap of about 1 cm at the wall on the connection side, as shown in figure 6. In this area the single-core connection cable will be placed.

To get a level surface, lay insulation over the entire floor, even where no foil will be laid.

Fix the insulation sheets with tape, as shown in figure 6, to stop them moving around while you are working. Cut away the insulation above the flexible conduit.

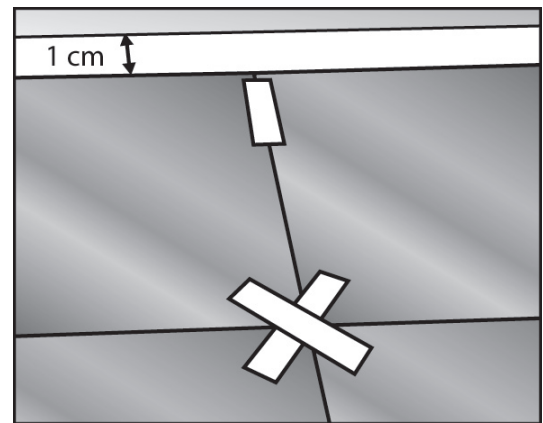

fig. 6

Measure up the foil and cut it

Roll out the foil to the correct length. On the connection side, end the foil about 4-5 cm from the wall. Using scissors, cut the foil square along the broken lines, as shown in figure 7. DO NOT cut into the black areas. The distance from the cut edge to the black area must never be less than 3 mm. Use the fixing tape supplied to tape the long sides of the foil together. Fully tape the long sides.

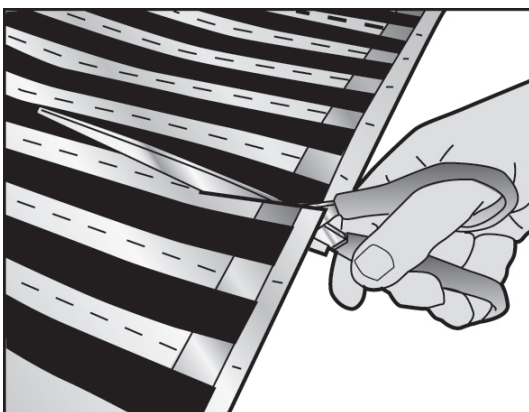

fig. 7

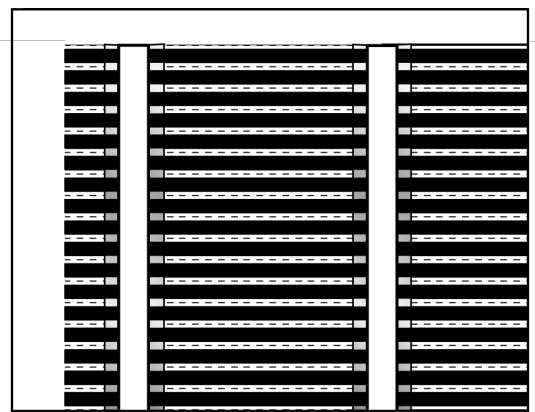

fig. 8

Seal off the copper strip

Seal off the copper strip with the round green pieces of tape, as shown in figure 9. Seal only the short side that will not be connected with cable.

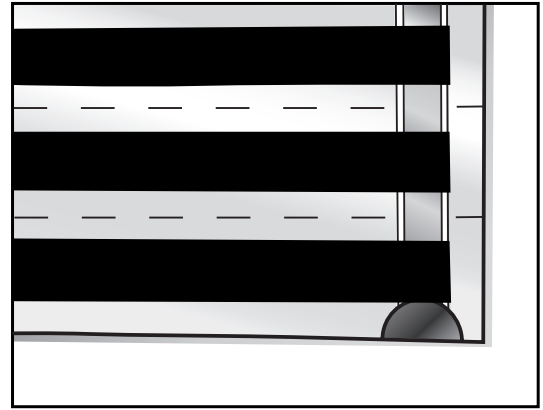

fig. 9

Cut out for the terminals and make space for the connection cable

Mark the insulation where the terminals will go, as shown in figure 10. Make a cutout of about 3 x 6 cm in the insulation. The terminals and the cables must not be protude of the upper surface of the insulation. Important!

Never apply mechanical load to the cables.

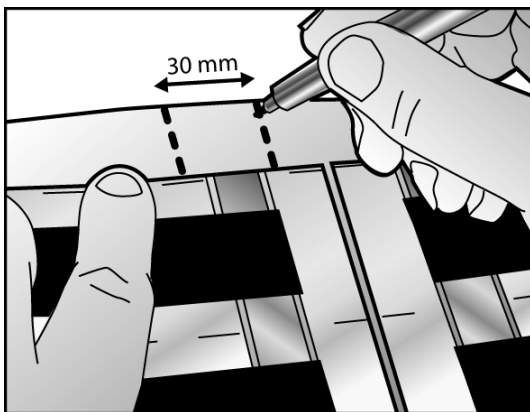

fig. 10

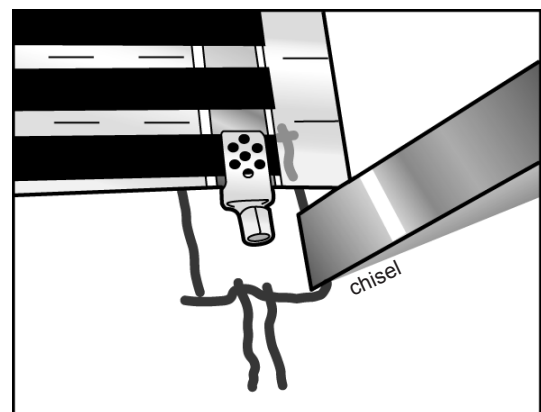

fig. 11

Adjust the crimping tool

For the terminals to be properly crimped, the pliers must be correctly adjusted. When the crimping tool is closed, the opening must not be larger than 1.3 mm. To adjust the crimping tool, unfasten the screw and turn the toothed disc on the side of the crimping tool; see figure 12.

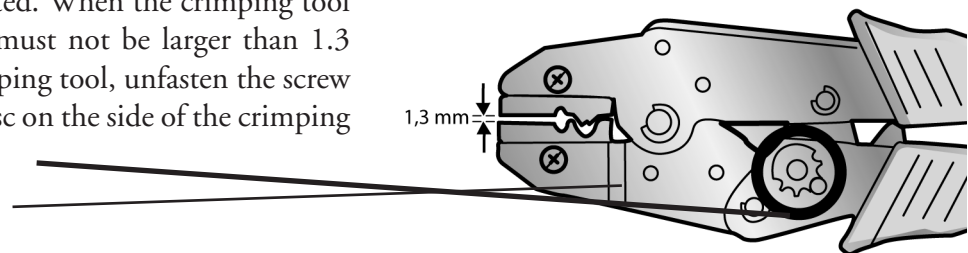

fig. 12

Fit the terminals

Slip the terminal on to the foil and centre it on the copper strip. Squeeze the terminal firmly with your fingers as shown in figure 13.

Crimp the terminal from both sides at an angle of 45° across the perforated part, as shown in figure 14.

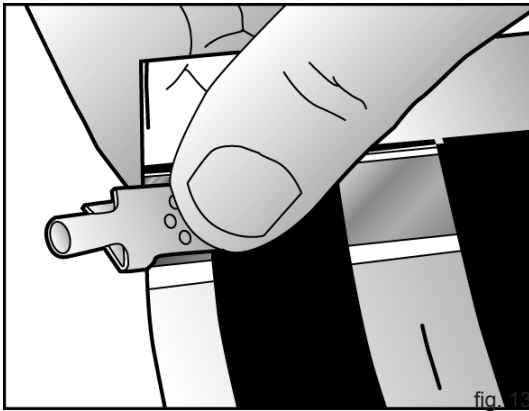

fig. 13

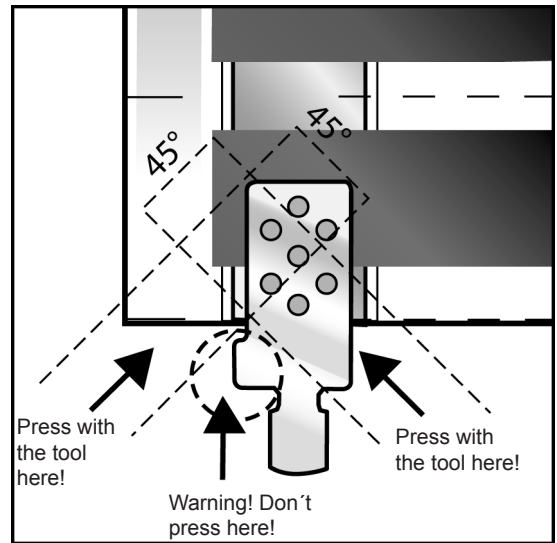

fig. 14

Connect the foils together

Connect the foils together as shown in figure 15. In an L-shaped room, the foils can be connected as shown in figure 16.

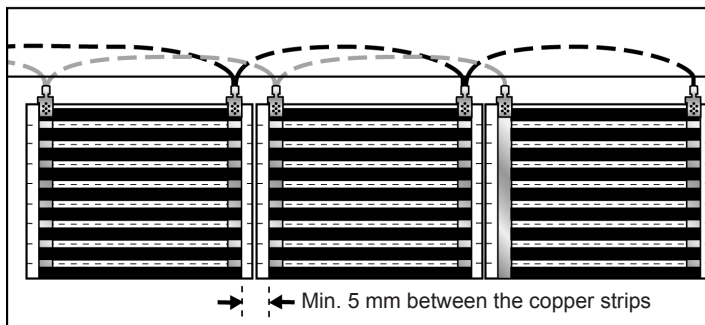

fig. 15

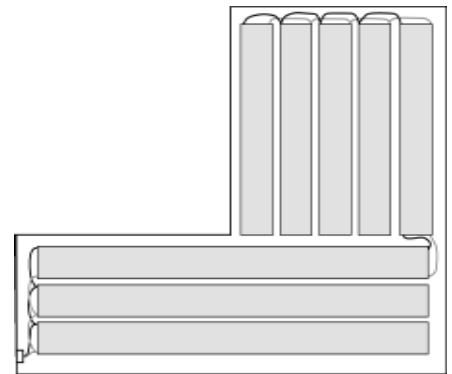

fig. 16

Run the cable

Fix the connection cables with tape etc in the cavity shown in figure 6. Cables can cross over in this cavity.

Important! Never apply mechanical load to the cables.

Connect the cables

Connect the lengths of foil together with the single-core double-insulated RTK cables supplied. Strip off about 6 mm of insulation and insert the wire into the terminal. If there is only one cable, bend the stripped wire double, as shown in figure 17. NOTE that the cables are double-insulated and that both insulation layers has to be removed.

Crimp the terminal to the cable with the crimping tool as shown in figure 18.

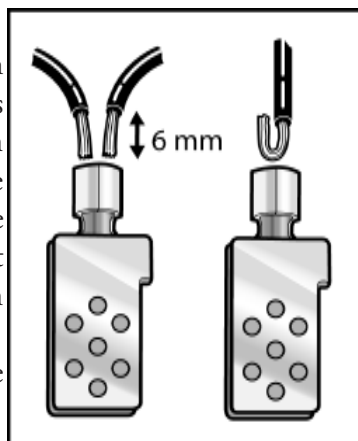

fig. 17

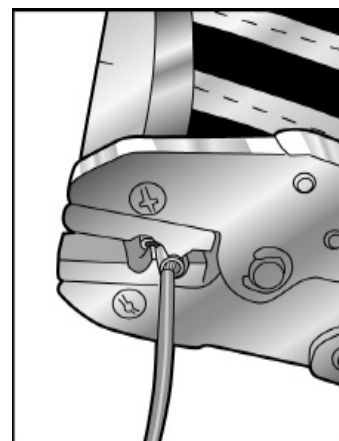

fig. 18

Insulate the terminals

Cut 50x25 mm pieces of the black insulating tape. Pull off the backing paper. Centre one piece of tape under the terminal and one over the terminal, as shown in figure 19. The tape must extend at least 5 mm beyond the end of the terminal. Press the insulating tape firmly together with your fingers.

Do not apply mechanical strain or load to the terminals.

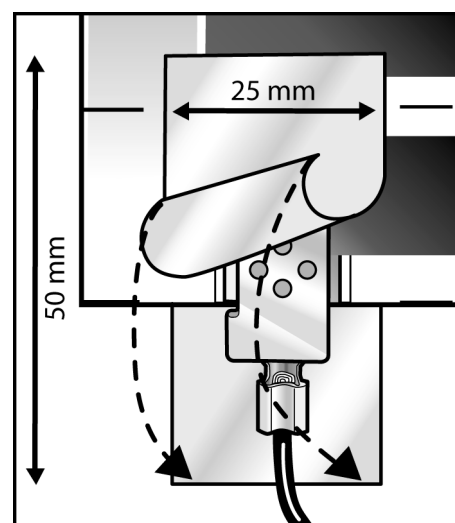

fig. 19

Test the foils

Measure the total length of the foils. Work out the theoretical resistance by inserting the total length into the formula in the test report. Enter the value in the report. Measure the resistance of the foils and enter the value in the report. Compare the theoretical value with the measured value.

The tolerance on the resistance values is -5% to +10%. Measure the insulation resistance of the foils and enter the value in the report. Make a record of the installation in the form of a photograph or a sketch, in accordance with the instructions on the guarantee certificate, please see page 7.

Cover with non-ageing plastic film and lay the floorcovering

Cover the foils with non-ageing plastic film, at least 0,2mm. When adding the next piece of plastic film overlap at least 200mm. Then lay the floorcovering immediately, in accordance with the arrangements illustrated on page 1. Some kinds of wood, especially beech and Canadian maple, exhibit more natural movement and are therefore not so suitable for underfloor heating. The floorcovering should be chosen with the guidance of the flooring supplier.

Test and connect the installation

After laying the floorcovering, test the foils. Enter the values in the test report. Keep a copy of the test report near the electricity distribution board. Connect the thermostat.

Guarantee Certificate

Lor Foil Kit 0.3

Lorenzoni srl provides a 10 year guarantee for defective materials in Lor Foil Kit 0.3 and Lor-Therm thermostats, henceforth called "the Products".

The guarantee only becomes valid under condition that the Products are installed by a qualified electrician according to the applicable regulations and in accordance with installation instructions. This guarantee certificate, including test record below, must be completed in its entirety and, along with the materials specification or invoice, must be signed by the electrician who carried out the installation. Furthermore, there must be photographs/sketches that show the Products in their entirety after laying but before covering.

If defects to materials should arise in the Products during the guarantee period, Lorenzoni srl undertakes to repair or alternatively replace the Products at no cost to the purchaser.

Lorenzoni srl also undertakes to restore the floor to its original condition after the repair or replacement has been completed. In order to be able to remedy the fault the purchaser must have saved or have access to 1 m² of the existing floor material. For thermostats, with defects that occur after 3 years Lorenzoni srl supplies a new thermostat.

*Applies only under condition that the product is installed indoors, together with Lorenzoni srl's control system.

The guarantee does not apply to installations that have been carried out by an unqualified electrician or alternatively if an unqualified electrician has carried out modifications or repairs. Nor does the guarantee apply if the defect has arisen as a result of using incorrect materials and floor construction or as a result of incorrect installation. Nor is damage covered that is a result of vandalism, fire, lightning, water damage or damage caused by negligence, abnormal usage or as a result of an accident.

In the event of a material defect arising that is covered by the guarantee Lorenzoni srl must be notified.

In the event of the guarantee being invoked, this guarantee certificate with accompanying invoice of installation, material specification plus completed and signed test record must be presented.

LORENZONI SRL
MICHELE LORENZONI

Electrical installation carried out by:

according to enclosed materials specification.

Date: -----

Signature: -----

Test Report Lor Foil Kit 0.3

Tolerance of resistance values: -5 to +10%. Min. Insulation value 10 Mohm.

230 V, 100W/m ² , width: 43 cm
$\frac{1322.5}{\text{length (m)}} = \text{theoretical resistance value}$

	Before laying	After fixing		After floor covering	
	Theoretical RESISTANCE- VALUE Ohm	RESISTANCE- VALUE Ohm	INSULATION- VALUE Mohm	RESISTANCE- VALUE Ohm	INSULATION- VALUE Mohm
Installed length (m):					
Installed length (m):					
Installed length (m):					

Mark your drawing with the respective number

If the floor surface is to be replaced, the new material must be suitable for underfloor heating. Contact your flooring supplier for information. Do not position insulating material or floor fixtures on surfaces where there is underfloor heating. This reduces heat transfer into the room and produces a higher temperature in the floor.

Length/Size	Power/Voltage
_____	_____
_____	_____
_____	_____
_____	_____
_____	_____

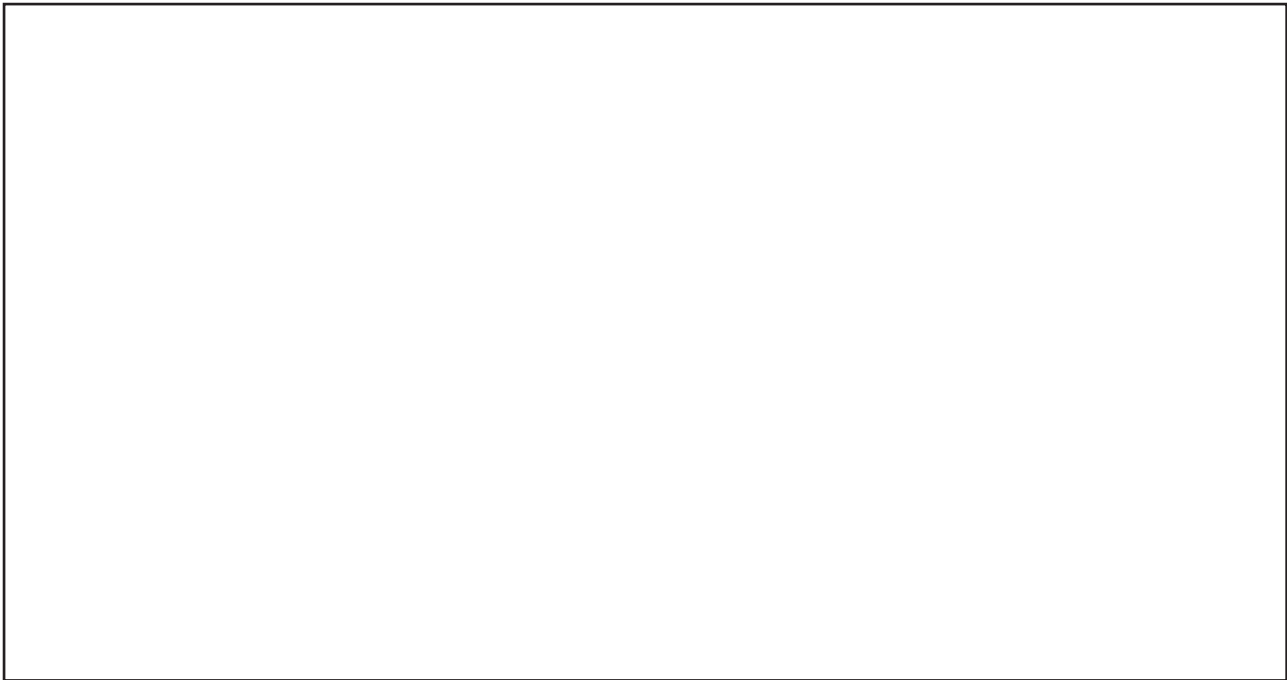

A detailed sketch of the terminations and splices in the foil, and the exact positioning of any connection boxes must be entered above. In addition, take a photographic record of the laying process. This sheet or a copy of it should be displayed beside the fuse panel.