

Lorenzoni Srl
Soc. Unipersonale
Via Molini 98/3
36055 Nove (VI) Italy
P.IVA e C.F. 02872270240
R.I. 02872270240 – R.E.A. 280950

CAVI SCALDANTI – RESISTENZE ELETTRICHE – TERMOREGOLAZIONE
HEATING CABLES- HEATING ELEMENTS – TERMOREGULATION

Tel. +39 0424 502042
Fax + 39 0424 502043
info@lorenzoni-srl.it
www.lorenzoni-srl.it

INSTRUCTION MANUAL

LOR-THERM 105

Cod. 523.0000.102



For the guarantee to be valid, the product must be installed and operated as indicated in this manual. This means it is extremely important that you read the manual. This applies both to the person installing the thermostat and the person who is going to use it. You will also find technical specifications and information on troubleshooting.



Important The underfloor heating system is an electrical power installation and must therefore be installed in accordance with the current regulations and under the supervision of a qualified electrician.

Introduction	20
In the pack	21
Installing the thermostat	22
How the thermostat works	26
Troubleshooting	31
Technical specifications	32

Introduction

This is a microprocessor-controlled thermostat for optimum regulation of underfloor heating systems. The front is fitted with a lockable knob for regulating temperature, as well as an on/off switch that shows whether the underfloor heating is in operation.

Temperature control is carried out by means of an algorithm that uses fuzzy technology. The technology entails the thermostat testing and collecting data from start-up, and based on this, calculating when to turn on and off. This technology reduces temperature variations and thus provides a more constant temperature and lower energy consumption. The floor temperature varies less than ± 0.3 degrees.

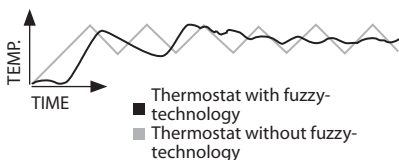

In the pack

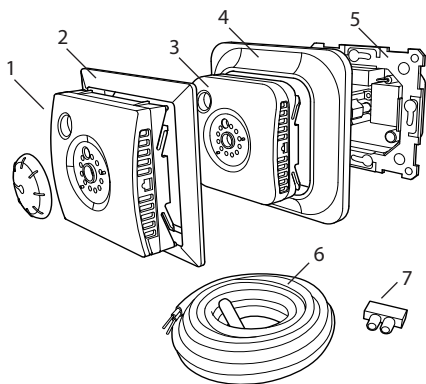

EN

1. Front for Elko RS, Elko Plus and Gira
 2. Adapter for Strömfors frame system
 3. Front for Eljo Trend, Merten, Jussi/
Busch-Jäger
 4. Frame
 5. Thermostat
 6. Floor sensor
 7. Connection clip
- Manual

Installing the thermostat

The floor sensor should be mounted in a spiral hose laid in the floor. The hose endings should be sealed so that the floor sensor can easily be replaced.

Installation

Mount the thermostat in a 65 mm standard appliance box.

1. Make sure the box is level with the wall.
2. Remove the knob and undo the screw as in the illustration. Lift off front and frame.

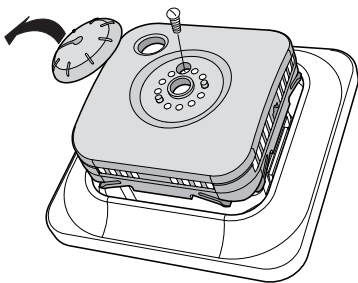

3. Connect power, voltage 230 VAC, load and floor sensor cable.

Any extension to the floor sensor cable must be by means of high-voltage current. Protective conductor for incoming feed and for heating cable is connected with a connection clip in the box. See wiring diagram below.

4. Insert the thermostat into the appliance box and screw tight with the existing screws.

5. Mount frame, front and knob.

6. If the thermostat is mounted in a multi-compartment frame, the internal corners of this frame must be removed.

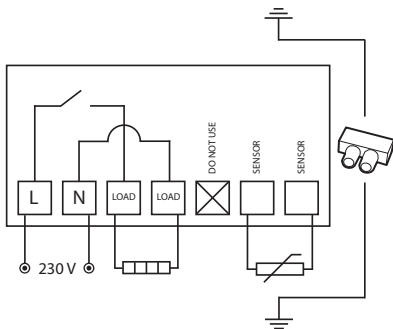

Getting started

After installation, wait 2-4 weeks before starting the underfloor heating. Precisely how long you wait depends on the type of floor you have and the instructions for the floor putty. Then increase the heat gradually.

In order to adapt the underfloor heating system to your own heating requirements as much as possible, it is important that you read the entire manual.

How the thermostat works

This section describes all you need to know about how the thermostat works and how you set it.

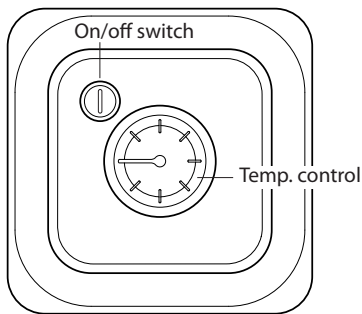

Turning off and on

The heating is not controlled in stand-by mode. Depress the on/off switch for a second to access stand by mode. Return to normal mode by once again depressing the button for a second.

Control functions

The thermostat can regulate the temperature in three different ways. This enables the comfort temperature and any flooring temperature requirements to be combined. How the settings are adjusted is described on the next page.

Floor thermostat (F) - A sensor in the floor measures the temperature and then regulates the heating accordingly. This is the factory setting.

Room thermostat (R) - The thermostat has built-in sensors for measuring the room's temperature and controlling the heating.

Room and floor thermostat (R&F) - The built-in sensor regulates the room temperature and the sensor in the floor functions as a floor temperature limiter. The limitation can be set to between 25°C and 45°C. The factory setting is 35 °C.

Important

In rooms with large windows that are exposed to solar insolation, we recommend the Room and floor thermostat *function*. In rooms with wooden flooring, the *Room and floor thermostat function* must always be used.

The adjustment of the regulating function, must be done by a qualified electrician. The knob and the front first have to be removed. Disconnect from power supply before removing.

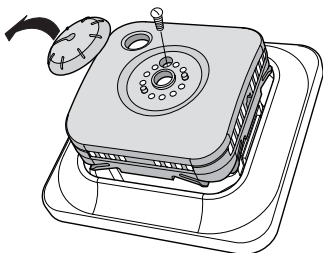

Then slide the control to the required position using a small screwdriver.

The overheating protection is adjusted here.

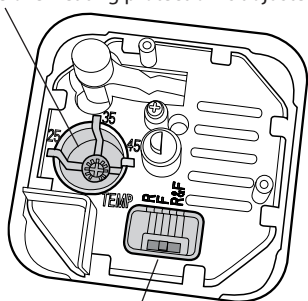

The regulating function is adjusted here.
F - Floor thermostat **R** - Room thermostat
R&F - Room and floor thermostat

Temperature

Regulating function

The thermostat regulates the temperature via a sensor in the floor that measures the temperature and regulates the heating accordingly.

Set the temperature required

Change the floor temperature by turning the knob. Min. position on the control corresponds to 10 °C, max. position corresponds to 45°C. An appropriate setting is usually between 2 and 3.

The temperature does not stabilise until the underfloor heating system has been on for a few days. It might then be necessary to adjust the thermostat's setting.

Indication

The colours on the on/off switch show the current status for the thermostat.

Red light - the thermostat is on and the underfloor heating is activated.

Green light- the thermostat is on and the underfloor heating is switched off.

Key lock button

When you have found a suitable setting for the temperature you can lock the knob. This prevents the control being changed accidentally.

See illustration below. First remove the knob. Then move the two plastic parts so that they define the interval required. Replace the knob.

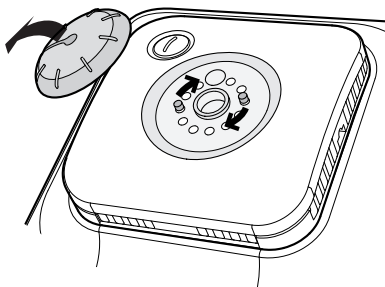

Troubleshooting

Important The underfloor heating system is an electrical power installation and any faults must therefore be remedied by a qualified electrician.

Fault indication

In the event of damage or breakdown of the floor sensor the thermostat switches off and the light starts to flash alternately green and red.

If the floor sensor should be defective it can be replaced, provided that it is installed in a spiral hose laid in the floor as per instructions.

Test values for floor sensor

The following values apply when the floor sensor's measurements are checked.

Temperature	Resistance
10°C	18,0 kΩ
15°C	14,7 kΩ
20°C	12,1 kΩ
25°C	10,0 kΩ
30°C	8,3 kΩ

Technical specifications

Voltage	230 VAC-50 Hz
Floor temp. range	10-45 °C
Breaking capacity	16A/230 VAC/Single-pole
Connection cable	max 2.5 mm ²
Load	cos φ = 1
Hysteresis	+/- 0.3 °C
Protection class	IP21
Max. length sensor cable	50 m, 2x1.5 mm ²

Approvals: CE Ⓢ